

MULTIVARIABLE PROCESS MODELL FOR COMPLEX VEHICLE SYSTEMS UNDER EXTREME LOAD ENVIRONMENT

Rózsás Zoltán¹, Dr. Hány András², Dr. Viharos Zsolt János³

¹*Autóipari Próbapálya Zala Kft, 8900 Zalaegerszeg, Fészek u. 4. (zoltan.rozsas@apz.hu)*

²*APNB Kutató, Fejlesztő és Szolgáltató Kft., 8900 Zalaegerszeg, Gólyadombi út 3. (andras.hary@apnb.hu).*

³*Magyar Tudományos Akadémia Számítástechnikai és Automatizálási Kutatóintézete, 1111 Budapest, Kende u. 13-17. (viharos.zsolt@sztaki.mta.hu)*

Abstract – Vehicle industry is facing two megatrends nowadays: alternative drives and autonomous vehicles. Extreme loads have crucial importance inside these trends, too. Unforeseen events happening in real life can be considered as special form of extreme loads, this is the key novelty of the paper together with the presentation that the classical 6 sigma approach applied typically e.g. in production environments can be used to describe this special form of extreme loads. Various examples represent the applicability of this proposed concept like extreme loads at vehicles of heavy weight & low speed (tractor), light weight and high speed (formula car) and autonomous vehicles. Finally, a concrete vehicle route in a city was analyzed with evaluation of unforeseen events highlighting the advantages of the proposed concept.

I. INTRODUCTION

The changes in the automotive industry is heading in two ways (alternative propulsion technologies and autonomous driving control), while the extreme challenges are getting more important. These give required information for (for example) designing, scaling and are specify the lifespan of the vehicles. But, extreme challenges have more, different aspects.

The vehicle control's planner-intervening algorithms are usually made in such a manner, that they can be pre-modeled simulated and repeated. In the real working environment, there are plenty of non-foreseeable events, (here: extreme) occur, so it's vital to call non-foreseeable and non-plannable extreme challenges. The article shows these special challenges and demonstrate the 6-sigma process, analog method of approach in relation to the vehicle's systems, programs, which is usually used in process control and defines the extreme challenges.

The first chapter shows the automotive megatrends through that the importance of the extreme challenges, followed by their definition. The connecting research's presentation is followed by the statistical presentation of the extreme challenges, recommended technologies and manufacturing systems. The next part show two, specified vehicle systems: (great mass, small speed(tractor); small mass, large speed (formula car)) with which it presents the extreme challenges' definition,

completed with the description usable on autonomous vehicles. Before the summary, there's a given test route, with unexpected occurrences, as extreme challenges show the advantages of the recommended description. The article is closed by thanksgiving acknowledgements and references

II. TRENDS OF THE AUTOMOTIVE INDUSTRY

The researches in this article connect to the changes in the industry, which relate to the global evolutionary processes (megatrends). The changes in the automotive industry can be divided into two major parts, from which nowadays research challenges are understandable:

- changing the fossil fuels to new, alternative energy sources [1],
- Making changes towards autonomous car control [2].

If we consider the automotive trends, the importance of non-plannable and hardly reproducible phenomenon in car control (see: autonomous vehicles; connected-cars). So, the researchers are focused on special occurrences' interpretation, the classical 6-sigma analog approach, with the vehicle-systems' pilot programs.

2.1. The emergency of extreme loads

Nowadays, the autonomous vehicles' research and development is in the focus of the science and industry, because of the advantages of these vehicles: Better safety, smaller emission, less traffic jams, larger mobility. The key to autonomous solutions are the background software, and the detection-intervention system's constant feedback [7]. Katrakazas et al., The relevant terms in car control has been agreed upon in 2015: Path, maneuver trajectory, and the planning of these. The compilation contains on overview on various intervention strategies (e. g. the maximization of the distance between car and environment, the optimization of availability grid, the minimization of the cost of usage, etc.) [7] The optimal planning is the following:

- the realization of the best possible route
- choosing the best maneuver to complete the planned route
- the best trajectory for the optimization of the maneuver

the tests of DARPA Urban Challenge, 2007 showed, that the planning of maneuver shall be able complete to motorized and non-motorized situations.[8]. In this case, it's vital to foresee the obstacles and situations.[9]. Through our researches, the "motion modelling" gives physical, maneuver and interaction models. As soon as the required information is in our hands, the decision mechanics are mostly known.[10]. At this point, we reach to the definition of the extreme load, which are the crucial properties of the cars test and usage handling. The vehicles' planning-intervening algorithms can be written if the situation is pre-modellable, can be simulated, known and can be reproduced. But in the real usage environment, there is a lot of situations, which cannot be foreseen. (called extreme), the handling of these can only be expected if the system is a high-intelligence one, with ability to learn. There is relatively little research in this field, the combination of vehicle handling, extreme loads and challenges, the usage-test of vehicles is, according to our informations, a pretty low priority of research yet. For safety and reliability, the conduction of a lot of tests is required [11] and that's why the tests in extreme situations is worth considering. One of these extreme situations is the hardness, caused by weather and visibility. [12]. The extreme loads in case of vehicle handling show some analogies with the extreme loads in case of mechanical systems. [13].

III. EXTREME LOAD OF VEHICLES

3.1. The definition and situations of extreme load

It's vital to clarify the definition of the definition of the extreme loads, since we can grade the loads affecting the vehicles. It's important to specify in every simple or complex situation, can make an extreme load. In this case, even the industrial literature is split.

In a normal situation, there's usually 3 forces affecting the car in the direction of the movement, specifying the dynamics, speed and acceleration of the vehicle. We can understand these as loads, awakening at the edge of the road and the wheels, which the chain of drive shall defeat or bear.

It is called extreme load [] if the tested loads' average is higher, then the triple of the cars normal load, during the 99% of it's lifespan.

$$\Delta\delta + 3S \leq \delta_{szel} \quad \text{or} \quad \Delta\delta - 3S \geq \delta_{szel}$$

- $\Delta\delta$ – average
- S – dispersion
- δ_{szel} – extreme load

The definition shown on the dispersion curve; the part which is outside of the curve is considered to be an extreme load, let it be extremely high or low. (2. illustration).

2nd diagram. Illustration of extreme loads with normal distribution curve

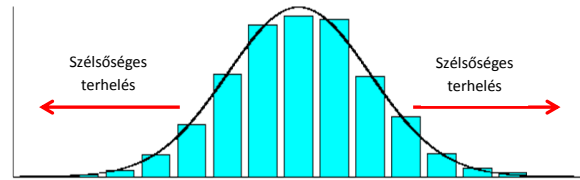

3.2. The statistical description of extreme loads

There are a lot of mathematical and statistical methods, with which we can simulate the emergence of the situation. [3]. In engineering, we usually assume the normal distribution, so we use the average of the measurement. [4][5][6].

If we have enough measurements or observations, we use the averages of them. There are cases, when the initial distribution or the density is unknown, so we assume a null-hypotesis a given distribution, then examine the signification. According to Gumbel's research [3] there are three models depending on the initial data for specifying the extreme datas and their frequency:

1. The initial distribution is known. Then, the extreme values can be calculated by analytic formulas, using the order-statistics.
2. The initial distribution is unknown, but through observation, we have the data. We can estimate the values by approximation methodes.
3. The initial distribution is unknown and we only have the maximum of the data. Then with extreme values is the asymptotic extreme value distribution statistics can be calculated.

In the design of machines and machine systems, to prevent structural faults, the marking of extreme loads is required in the sizing.

The extreme value is, what we define after a given number of observations show the greatest values. This can be given in different ways on a pattern. It can be for example.: difference from the median 1,5 – 3 times. the observation can be short term (30 minutes or some hours) and long term (several years).

3.3. The analogy of vehicles and manufacturing systems

If we observe the vehicle-testing as process, several outputs are plausible (the number of these depend on the complexity of the system, it can be hundreds in extremes situations) but the most important value can show two values, OK and NOK, since the only acceptable result of autonomous vehicles is a 100% safety.

It is see able that the definition of the extreme loads (six-sigma method), and the description of conditions (OK/NOK) shows analogy, previously well-tried in manufacturing systems, for example statistical monitor-intervention, lean principles, etc.

IV. EXTREME LOADS WITH SPECIAL VEHICLE SYSTEMS

The extreme loads special presentation of two extreme vehicle described in the following two sub-heading, which will be presented as an example of the supposedly causing extreme load events, operating conditions and situations. The selected vehicle is one of a lightweight but

high speed, the other is a high-volume but low-speed vehicle. The two loads a specific vehicle in Formula 2.0 is uniquely adapted for racing cars, heavy duty vehicles and an Raba Steiger are derived, and the load cases outlined characterize other machines belong to this type of vehicle group.

The test loads to the normal operating environment, some normal probability events as occurring were formulated and presented in tabular form, given their frequency and circumstances of the event in text form.

4.1. In extreme loads, high-volume, low-speed vehicles

Extreme loads were collected basis of operating conditions of the tractor, taking into account the loads due to the terrain and environmental conditions and at work .(Table 1).

1.table. Load cases at massive, low-speed vehicles

#	Load Event	Description	Pre-occurrence during operation
1.	Goes into a huge pit	The wheel does not rely on the ground, the other wheel is divided into three weight force The wheel rests on the bottom of the pit. The four wheels are not evenly rests on the vehicle X twists around the wrist tense	Common
2.	Trailer (work device) resistance	negative direction of the Z-axis	Regular (normal)
3.	eccentric raised/ Suspended load	On the rear of the vehicle for example. Delivery of equipment. Torque around the rear axle.	Common
4.	Hillside slope, curves.	Uphill / downhill crosswise consists, passing. The distance between the support points of the weight force perpendicular to the plane fall. The vehicle is rotated about the X axis. Between the ground and the tire friction Y-Z direction occurs. When cornering, the supports can vary place.	Common
5.	Working with slope	The weight force because of the slope it has an along-track component , however, the pitch orthogonal component is reduced, the friction force is reduced.	Common
6.	Working on deep, muddy ground	The towing resistance increases. The wheels sink into the deep soil, rolling resistance increases.	Common

#	Load Event	Description	Pre-occurrence during operation
7.	Working on dry, hard soils	The towing resistance increases. Adhesion between the tire and the ground decreases, the wheels slip.	Common
8.	Leans to the side during plow	During plowing one side of the wheels run on the previous furrow. The effect is similar to (4).	Regular (normal)
9.	During plowing, the plow stuck in something	During stuck, there is an opposing force to the connection points	Rare
10.	Start during load of the working tool	Between the front and rear sides of the vehicle's load distribution changes, the rear vehicle takes up half the retracting direction -X trailer load.	Common

The loads are considered to be those extreme loads that do not occur in the operating conditions or due to the dynamic nature of the structure can cause serious damages. The loads resulting from loads character satisfies the operating environment, since this structure is designed so that the pressures above security mechanisms are fitted, which prevent the breaking of the security elements of the tractor. For articulated heavy vehicles, the kingpin loads are a phenomenon of the most critical when the vehicle front and rear bodywork stochastic (time course can find defined form) character takes the form of interact, namely a vertically and horizontally positioned.

4.2. In extreme loads, low-mass, high-speed vehicles

The low-mass high-speed cars typically appear in racing sports, so the normal operating environment can be considered a race track, and the potentially occurring loads and events can be possible in this environment elements. The high speed of the vehicle normal load to determine the inventory of the vehicle loads occurring (Table 3).

3.. table, small weight, high speed

#	Load Event	Description	Pre-occurrence during operation
1.	Kerb at turning	When turning, the centrifugal force Y direction of vibration during start-up to kerb, the car lifted off the track one or more wheels of the plane, changed the weight distribution of power between the wheels and the ground (Z direction of the force).	Common

#	Load Event	Description	Pre-occurrence during operation
2.	Side impact with another vehicle	The conflicting vehicle X and Y component gives impact force at the collision site	Rare
3.	Sudden braking, acceleration	The inertia of the X-axis direction against the direction of movement changes between. slippage can occur between the tires and the track. The vehicle turned around Y. The load between the first and rear wheels changes.	Common
4.	High-speed turning	From the centrifugal force, in the direction of Y for the car and on the road, an opposite Y direction	Regular (normal)
5.	Driving on the fault of the road	One of the wheels lift off, the weight balance on axis Z changes to the other wheels	Frequent
6.	Driving on alien object	Sane as 5, but with larger effect	Rare
7.	Puncture	1. The back wheels lost their role as power transition, the balance becomes asymmetric; Torque affects the car by axis Z 2. The support changes, rotation on axis X	Rare
8.	Sudden wind from the side	Depending on the direction of the wind X-Y force.	Short-term, frequent
9.	Kerb from the front, while slipping	The front wheels hit the kerbs, X and Y axis forces affect them. Leaving the kerbs, the whole weight lies on the rear wheels. The car, advancing and rotation on axis Z falls on the bottom plate. Z force affects the surface. The rear wheels hit the kerbs, X and Y axis forces affect them. Leaving the kerbs, the whole weight lies on the front wheels.	Rare
10.	Driving on irregular terrain	In the deep ground, the wheels sink, the resistance gets higher (-X force), the bottom plate hits the gravel (-X force)	Rare
11.	Slipping, spinning	Rotation on axis Z.	Rare
12.	environment	At high temperatures, the drive may overheat.	Frequent

On the third figure, it shows how each occurrence affect the car, and where; which load, affects which part.

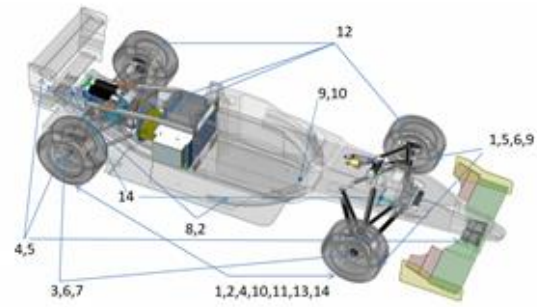

3rd diagram. Vehicle load map – categorized effects

It is clearly visible on the diagram, that the concentrated load is forces on the suspension. Because the load is not focused only on the front wheels it takes effect on the chain of propulsion. However, it is necessary to do a detailed examination and modelling. Since the folded wheel has a direct connection with the propulsion chain, the road surface and considering given race cars they set the width of the vehicle, in this way it is unavoidable that most of the load appears here

4.3. Defining extreme situations on autonomous vehicles.

During standard driving the driver is capable to handle unexpected situations. It is possible to base an algorithm on a part of these decisions but the other part is intuition based. The integration of these functions is easier to the vehicle control system. It is hard to translate intuition based decisions into algorithms. The different AI based systems are only a partial solution to the problem. Because of this, it is vital in a HAV to handle unexpected situations properly. From the point of validation this means a testing environment must be capable to generate these kinds of situations. The analogy of the topic is the monitoring-intervening, known from session control (4th diagram). The point of this, is that if we have sufficient data, we can make a diagram, which is unique and specific to the situation.

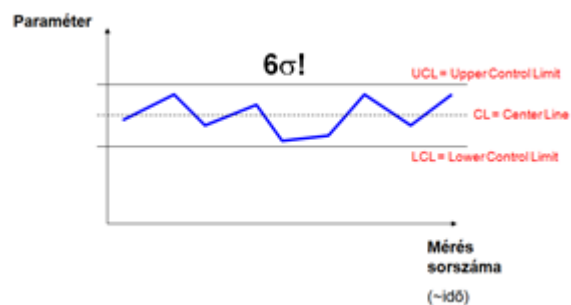

4. Diagram: Statistical process controll during the extreme load

V. UNEXPECTED EVENTS LIKE EXTREME LOADS

This chapter contains the records of an experiment which was executed on a 10 km road – all rules observed – while a camera recorded every traffic situations and events during the trip.

The complete video gets evaluate. Every event gets categorized by the types and frequency of the events.

5.1. Unexpected events on a city test route.

The circumstances of the test are the following:

- Time of the experiment: 13:21 - 13:36;
- Length of the trip: 14 min. 28 sec.;
- Start point: 8900, Zalaegerszeg Posta street 63.
- Finish line: 8900, Zalaegerszeg Fészek street 4.
- Vehicle used in the test: Mercedes G 350 W463.

Phenomenons experienced during the test can be classified into 4 risk levels depending on the possibility of an accident:

- level 3: high-risk event: confusing traffic situations
- level 2: mordent-risk events: huge vehicles. cyclists, turning vehicles
- level 1: vehicle or pedestrian
- level 0: normal firm: road.

The 5th diagram shows every risky situation from 1 to 3 based on time and quantity, which occurred during the test.

5th diagram. Unexpected events as extreme load situations. based on time (top) and based on quantity (bottom)



Result of the experiment supports the ground of statistical processing regulations. For example: chances of high-risk situations are low but they still happen during practical functioning.

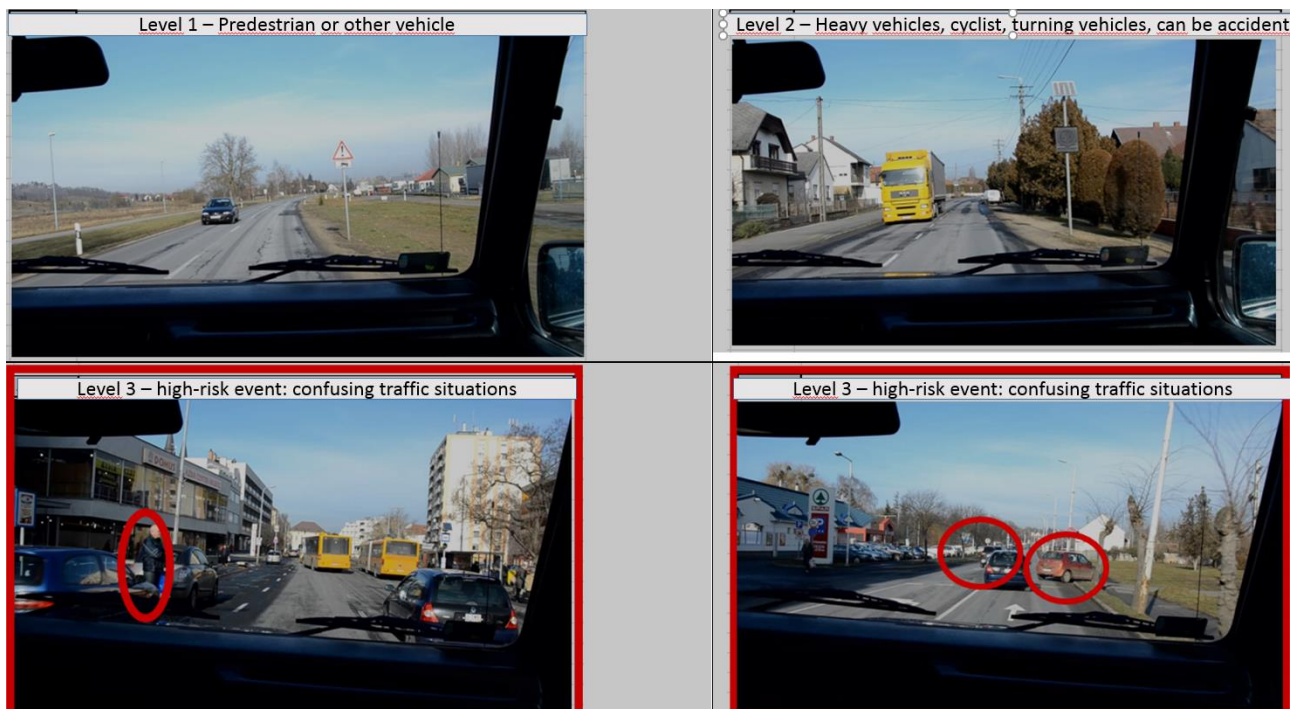

6. Fig. Unexpected events like extreme situations

6. SUMMARY

The article shows the importance of the extreme loads and the various ways to examine them. The vehicle control has pre-calculatable and reproducible algorithms, but may meet unforeseeable situations. The discreet attitude of these loads leads to the fact that they are describable by statistics. This leads to the fact that these vehicles have analogies with the manufacturing systems and the 6-sigma method. Based on these revelations, some extreme loads have been reviewed, showing finely the usage of this toolset:

- extreme loads on vehicle with huge weight and slow speed,
- extreme loads on vehicle with small weight and high speed,
- Interpretation of extreme loads in the case of autonomous vehicles,
- unexpected situations, as extreme loads, at an urban test route.

The shown examples illustrate the unexpected situations as extreme loads, description with for example the 6-sigma method.

12. ACKNOWLEDGEMENTS

The research is part of the VKSZ_12- 1-2013-0038: "Strategic, industrial sectors' futuristic manufacturing technologies and products' research and development project, in the region" project and is supported by it.

13. LITERATURE

- [1] Katrakazas, C.; Qudus, M.; Chen, W-H.; Deka, L.: Real-time motion planning methods for autonomous on-road driving: State-of-the-art and future research directions, *Transportation Research Part C* 60, 2015., pp. 416–442.
- [2] Burns, A vision of our transport future. *Nature L.D.*, 2013., Vol. 497, pp. 181–182.
- [3] Gumbel E.J.: *Statistics of extremes*, Columbia Press, New York 1958 Ochi M.K.: On prediction of extreme values, *Journal of Ship Res.*, Vol. 7., 1973, pp. 29-37.
- [4] Simiu, E.; Heckert, N. A.; Filliben, J. J.; Johnson, S. K.: *Extreme wind load estimates based on the Gumbel distribution of dynamic pressures: an assessment*, Elsevier Structural Safety. 2000.
- [5] Quan, Y.; Gu, M., Tamura, Y.; Chen, B.: *An Extreme-Value Estimating Method of Non-Gaussian Wind Pressure*, The Seventh Asia-Pacific Conference on Wind Engineering, 2009.
- [6] Gmach, D.; Rolia, J.; Cherkasova, L.; Kemper, A.: *Workload Analysis and Demand Prediction of Enterprise Data Center Applications*, Workload Characterization, 2007. IISWC 2007. IEEE 10th International Symposium.
- [7] Falcone, P.; Borrelli, F.; Asgari, J.; Tseng, H. E.; Hrovat, D.: *Predictive Active Steering Control for Autonomous Vehicle Systems*, IEEE Transactions On

Control Systems Technology, 2007

- [8] Fletcher, L., Teller, S., Olson, E., Moore, D., Kuwata, Y., Leonard, J., Miller, I., Campbell, M., Nathan, A., Kline, F., The MIT – Cornell collision and why it happened. 2008, *J. Field Robot.* 25, 775–807.
- [9] Lefèvre, S., Vasquez, D., Laugier, C., A survey on motion prediction and risk assessment for intelligent vehicles. *ROBOMECH J.*, 2014. Vol. 1., pp. 1–14.
- [10] Furda, A., Vlacic, L.: Enabling safe autonomous driving in real-world city traffic using multiple criteria decision making. *IEEE Intell. Transp. Syst. Mag.* 2011, Vol. 3, pp. 4–17.
- [11] Dokic, J., Muller, B., Meyer, G.: *European Roadmap Smart Systems for Automated Driving*, European Technology Platform on Smart Systems Integration, 2015.
- [12] Yu, R., Xiong, Y., Abdel-Aty, M.: A correlated random parameter approach to investigate the effects of weather conditions on crash risk for a mountainous freeway. *Transport. Res. Part C: Emerg. Technol.* 50, 68–77.
- [13] Maghsood, R.; Rychlik, I., Wallin, J.: Modeling extreme loads acting on steering components using driving events, *Probabilistic EngineeringMechanics*, 2015, Vol. 41., pp. 13–20.